

PROPOSED SPECIFICATION FOR ALUCOBOND PLUS
Aluminium Composite Panel Cladding System
Fixed Watertight Cassette Panel System - 4mm thick

1. SCOPE OF WORK

The scope of work includes the design, supply fabrication and installation of Alucobond PLUS aluminium composite panel cladding, complete with all necessary sub-structures, anchors, hardware and fittings to provide a total installation, fully in conformity with the requirements and intent of the drawings and specification herein.

The cladding system shall be installed complete with matching copings, flashings etc. by an approved cladding specialist subcontractor in accordance with the manufacturer's recommendations.

2. DESIGN CONCEPT

The proposed Alucobond PLUS cladding shall be based on a watertight cassette panel system and divided into individual panels as indicated on architectural drawings.

A typical panel shall be fitted with extruded aluminium angle brackets. Such brackets shall be positioned in such a manner that brackets attached to adjacent panels shall overlap.

Fastening of panels shall take place and be concealed within the panel joints through the overlapping angle brackets into furring channels behind.

A construction joint of 12mm minimum shall be provided between cladding elements to cater for easy panel installation. All fixing and joint details shall be designed to provide for the expected thermal and structural movements.

To conceal fixings and form a watertight seal, seal construction joint with a suitable silicone or polyurethane sealant over a closed cell foam backing rod. Sealant applied to be of a type in accordance with sealant manufacturer's recommendations.

Horizontal cladding areas ideally should have a slope of 1:15 (4° approx) and to prevent staining should slope away from visible vertical facade areas.

3. DESIGN CRITERIA

All Alucobond PLUS composite panel cladding shall be so designed to meet or exceed specified performances required for the prevailing local weather conditions.

- 3.1. Design Wind Loading : _____ kPa positive and negative
No cladding element shall sustain permanent deformation or failure under loading equivalent 1.5 times the design wind pressure specified.

PROPOSED SPECIFICATION FOR ALUCOBOND PLUS

Aluminium Composite Panel Cladding System

Fixed Watertight Cassette Panel System - 4mm thick

3.2. Deflection: Deflection of any aluminium frame shall not exceed 1/150 of the clear span.

3.3. Expansion and Contraction

The cladding shall be so fabricated and erected as to provide for all expansion and contraction of the components. Any temperature change due to climatic conditions shall not cause harmful buckling, opening of joints, undue stress on fastening and anchors, noise of any kind or other defects.

3.4. Flatness

With a gloss of 30% according to GARDNER Scale, the cladding surface taken individually shall not have any irregularities such as oil canning, waves, buckles and other imperfections when viewed at any position but not less than at an angle of 15 degrees to the true plane of the panel, with natural lighting of incident of not less than the same angle.

4. MATERIAL AND FINISHES

4.1. Cladding Material

All cladding shall be 4.0mm thick Alucobond PLUS aluminium composite panel comprising a core containing not less than 70% non combustible mineral filling sandwiched between two skins of aluminium alloy PERALUMAN-100 EN AW-5005 A (AlMg1-NS41)

- | | | |
|-----|---------------------------------|--|
| (a) | Aluminium skin: | 0.5mm thick |
| (b) | Mechanical Properties: | : Tensile strength ≥ 130 N/mm ²
0.2% proof stress ≥ 90 N/mm ²
Elongation $5.65 \sqrt{S_0} \geq 10\%$
Modulus of Elasticity 70,000 N/mm ² |
| (c) | Vibration:
and Noise Damping | Average airborne – sound transmission loss
R _w 26 dB (DIN 4109) |
| (d) | Rigidity (E x I) | : 0.240 kNm ² /m |
| (e) | Panel weight | : 7.6kg/m ² |

PROPOSED SPECIFICATION FOR ALUCOBOND PLUS
Aluminium Composite Panel Cladding System
Fixed Watertight Cassette Panel System - 4mm thick

(f) Finish

The external cladding panel surface shall be factory prefinished by the manufacturer with a Fluoropolymer coating of either PVDF or FEVE or combination of both applied through a "REVERSE ROLLER COATING" process. Total dry-film thickness of the coating shall be 25 microns minimum consisting of a chromate conversion coating, an inhibitive primer and a top coat. The coated surface shall comply strictly with:

- EN13523 "Coil Coated Metals – Test Methods" as required by ECCA (European Coil Coating Association) to achieve The Quality Label Category 1.
- AAMA 2605-11

The finished surface shall be factory protected with a self-adhesive peel-off foil, tested to withstand at least 3 months exposure to local weather conditions without losing the original peel-off characteristic or causing stains or other damages.

Application of the Fluoropolymer coating system by means of spray coating before or after forming and shaping of the cladding elements shall not be permitted.

The reverse side of the cladding panel surface facing the wall shall be in mill finish.

- (g) Colour/Gloss : As per ALUCOBOND® standard colour chart with approx. 30% gloss according to GARDNER scale

4.2 The Alucobond PLUS ACM shall be CodeMark Certified for use as external cladding on buildings of type A, B & C construction according to BCA Certificate of Conformity Number GM CM 30070, Fire Product Assessment 2305360, and tested in accordance with Australian and International Standards listed below.

Test	Description	Result
AS 1530.3	Simultaneous determination of Ignitibility, Flame Propagation, Heat Release and Smoke Release"	Ignitability Index 0 Flame Propagation 0 Heat Release 0 Smoke Release 0-1
ISO 9705	Full scale Room Test For Surface Products	Group 1 Material according to BCA Specification C1.10.4 (b) (i) SMOGRA 1.385 m ² /s ²
EN1305.1	Classification Of Reaction To Fire Performance	B – s1,d0
DIN 4102.1	Fire Behaviour of Building Material & Elements	B1
UBC 26-9	NFPA 285 Intermediate Scale Multi Storey Flammability Test	Passed

4.3. Aluminium extrusions

Non visible extrusion shall be of aluminium alloy AA 6063-T5 in mill finish.

2017 Alucobond Plus Fixed Watertight Cassette Panel System - Painted

PROPOSED SPECIFICATION FOR ALUCOBOND PLUS

Aluminium Composite Panel Cladding System

Fixed Watertight Cassette Panel System - 4mm thick

4.4. Fixings

- (a) Fasteners, including concealed screws, nuts, bolts and other items required for connecting aluminium to aluminium or aluminium to steel shall be in accordance with AS 3566.2 and of a type to suit its application and exposure conditions.

Class 1 and 2: Internal applications.

Class 3: External applications, moderate industrial and marine applications.

Class 4: Severe marine applications

- (b) Blind rivets used for fastening Alucobond PLUS panel to aluminium sub-frame shall be of aluminium alloy with stainless steel mandrel.

- (c) All fixing anchors, brackets and similar attachments used in the erections, shall be of aluminium, non-magnetic stainless steel, zinc coated steel, or hot dip zinc galvanised steel.

4.5. Dissimilar Materials

Where two surfaces of dissimilar material come into contact, such surfaces shall be insulated with a layer of PVC or Polyethylene tape.

5. FABRICATION

- 5.1. All cladding panels shall be factory fabricated and assembled in compliance with the manufacturer's Data Sheets and to the best standard of workmanship under experienced factory supervision and control.

- 5.2. All panels shall be cut and routed using equipment and tools recommended and approved by the panel manufacturer. After folding into cassettes, an extruded aluminium profile shall be fixed to the minimum 20mm deep return bend using \varnothing 5mm blind rivets.

Rivets shall be properly positioned not less than 15mm from the edge of the Alucobond PLUS panel and the distance between rivets shall not exceed 500mm.

The corners of the panels shall be as per manufacturer's drawing No. 6.6.10. (attached)

- 5.3. If reinforcement of the panel will be required, an extruded aluminium profile of suitable cross-section and strength shall be bonded to the reverse side of the Alucobond PLUS panel using "3M VHB4991" or "Tesa 7078 ACX Plus" double sided tape. Application of bonding systems shall be in strict conformity with the manufacturer's specification and recommendations. The ends of the stiffener shall be mechanically joined to the panel sub-frame.
- 5.4. Each panel shall be marked on the reverse side for easy identification of size and location.

PROPOSED SPECIFICATION FOR ALUCOBOND PLUS

Aluminium Composite Panel Cladding System

Fixed Watertight Cassette Panel System - 4mm thick

5.5. Finished panels shall be stored and transported to site in vertical position, face-to-face resp. back-to-back, with adequate protection to prevent scratches and dents.

5.6 The factory applied protective peel-off foil shall only be removed after the panels have been installed on site.

6. INSTALLATION

6.1 Panels shall be stored on site in vertical position, face-to face resp. back-to back-, with adequate protection to prevent scratches and dents.

6.2 Any component parts which are observed to be defective in any way, including warped, bowed, dented, abraded and broken members must not be installed. Member or parts which have been damaged during installation or thereafter before the time of final acceptance shall be removed and replaced.

6.3 No cutting, trimming, welding or brazing of any component parts during erection, in any manner which would damage the finish, decrease the strength or result in a visual imperfection or failure in performance shall be executed during erection. Component parts which require alteration shall be returned to shop for fabrication, if necessary replaced with new parts.

6.4 Anchorage of the cladding structure to the building structure shall be by approved methods in strict accordance to the specification and approved shop and/or erection drawing. Supporting brackets shall be so designed as to provide three-dimensional adjustments and accurate location of cladding components.

6.5 All component parts shall be installed level, true to line with uniform joints and reveals.

Maximum deviation for vertical member: 3mm max. in a 5.200m run and 5mm max. in an 11.00m run.

Maximum deviation for horizontal members: 3mm max. in an 8.500m run.

Maximum offset from true alignment between the abutting members shall not exceed 1.0mm.

The tolerance of the width of the joints between two panels shall be maximum \pm 2mm.

6.6 Cladding panels shall be left protected by the factory applied peel-off foil as long as possible. Under no circumstances shall the peel-off foil on individual panels be partially removed and left exposed to weathering.

6.7 Before handing over of the completed cladding, all peel-off foil shall be removed. Panels which were exposed to weathering without peel-off foil shall be cleaned in accordance with manufacturer's recommendation.

PROPOSED SPECIFICATION FOR ALUCOBOND PLUS
Aluminium Composite Panel Cladding System
Fixed Watertight Cassette Panel System - 4mm thick

DETAIL OF CUT-OUT
TO CORNER

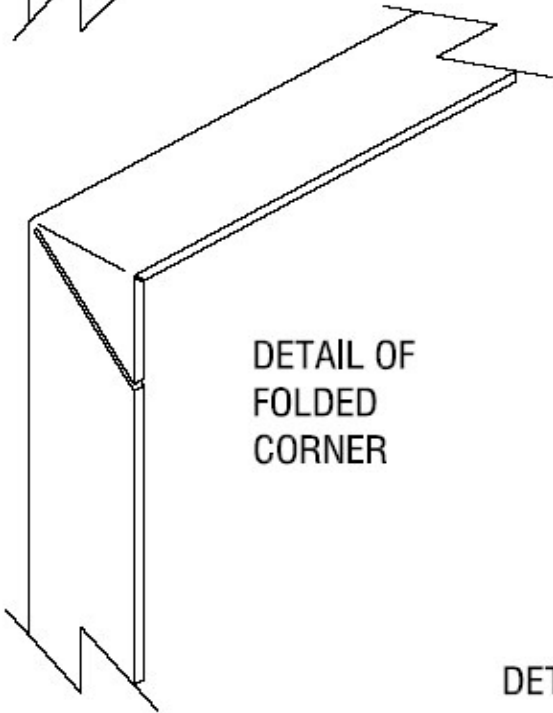
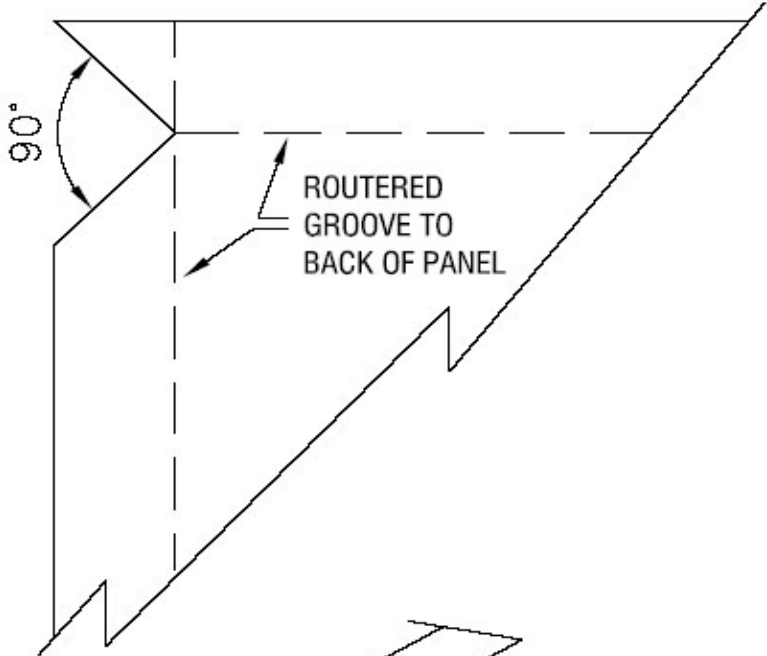

DETAIL SHEET 6.6.10